



Shown with X1 Process Fitting  
Imperial Conduit Entry

## SURPASSING SENSITIVITY FOR THE TOUGHEST APPLICATIONS

The VRF<sup>®</sup> II Series uses radio frequency to detect the presence or absence of material in a vessel. It compensates for the load of the probe and vessel environment to automatically determine the optimal operating frequency for the greatest sensitivity and stability.

## FEATURES AND BENEFITS

- **Universal Input Power** provides flexibility in location of the unit
- The VRF II can automatically calibrate itself when the probe senses a large decrease in the impedance with **EZ-CAL<sup>®</sup> II**
- **Adjustable Time Delay** allows the user to determine time between sensing material and the alarm state. Advanced units can permit delays when it detects the presence and absence of material or a combination.
- **Sensitivity Settings** can be selected to fit specific applications and material requirements.
- Probes have been designed with **Pro-Guard<sup>®</sup>** that has the ability to ignore the effects of coatings that can adhere to the probe
- Move electronics up to 100 ft (30 m) away with the **Remote Option**
- **Standard** and **Advanced** offering enables the user to choose the option that best suits the application
- Frame designed to enable connection flexibility
  - Imperial or Metric **conduit entry options**
  - **Process Fitting** can be made to fit any connection

## STANDARD VS. ADVANCED UNITS

STANDARD	ADVANCED
4 Sensitivity Settings (min 1.5 pF)	7 Sensitivity Settings (min 0.5 pF)
Time Delay up to 6 seconds	Time Delay up to 150 seconds
Manual, Push Button for Test and Calibration	Test and Calibration with FOB
Universal Power	Universal Power
	Indicator Lights
	Auxiliary Relay

# VRF® II Standard Unit

## VRF II - STANDARD UNIT

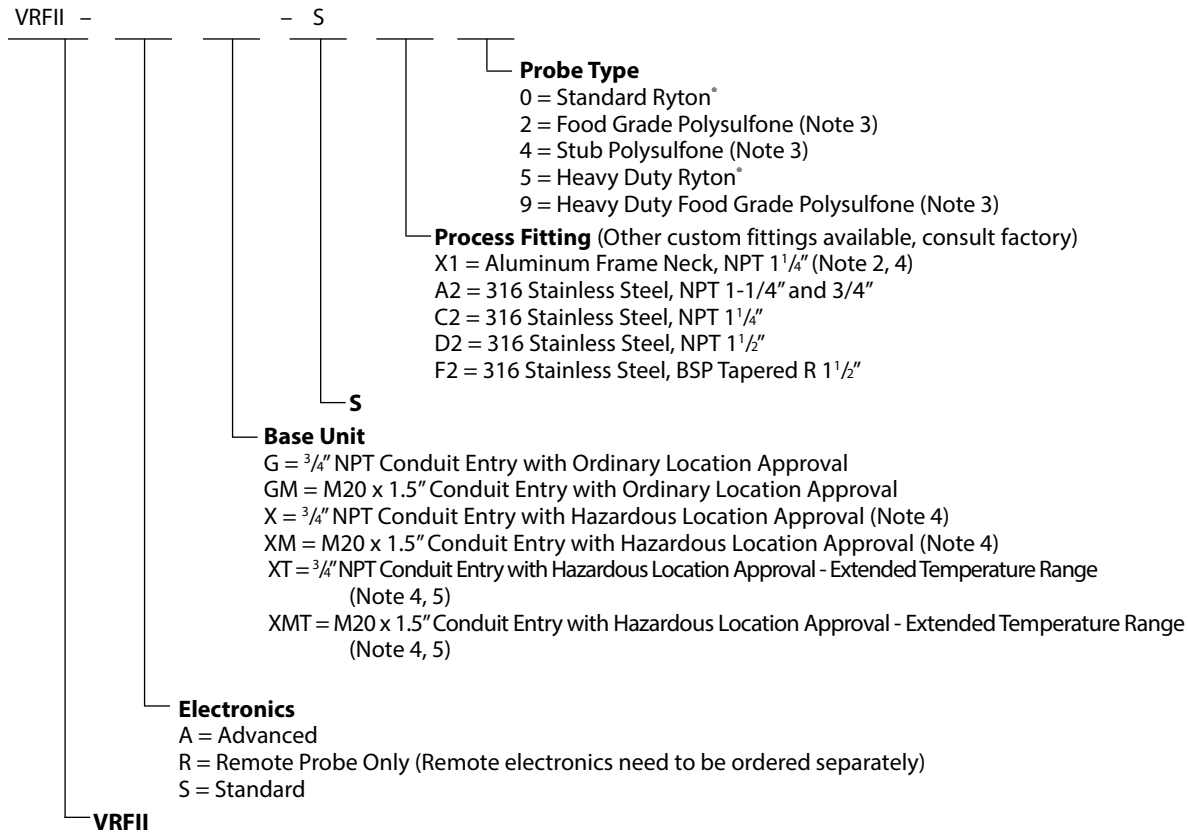

- Notes:
- Units have powder coated aluminum Housing Finish.
  - X1 Process Fitting includes a 3/4" NPT 316 stainless steel bin connector.
  - EPDM food grade gasket is standard.
  - Process Fitting X1 cannot be used with Hazardous Location Approval.
  - Extended ambient temperature range is -40° to 158° F (-40° to 70° C).

## STANDARD UNIT DIMENSIONS

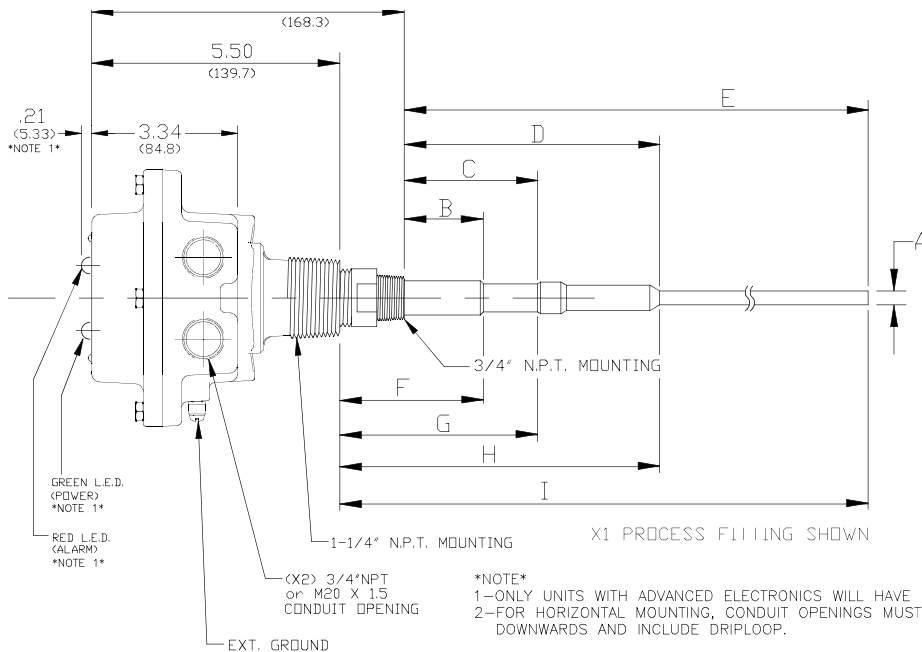

I	15.25 (387.5)	19.25 (489)	15.25 (387.35)
H	7.00 (178)	11.75 (298.5)	3.63 (92.2)
G	4.50 (114.5)	10.00 (254)	3.25 (82.55)
F	3.38 (86)	8.5 (216)	2.75 (69.85)
E	14.25 (362)	18.25 (463.5)	14.25 (362)
D	6.00 (152.5)	10.75 (273)	2.63 (66.8)
C	3.50 (89)	9.00 (228.5)	2.25 (57.2)
B	2.38 (60.5)	7.50 (190.5)	1.75 (44.5)
A	.31 DIA. (8)	.38 DIA. (9.5)	.31 DIA. (8)
APPROX DIM'S	STD. & FOODGRADE	H.D.	STUB
PROBE TYPE	0 & 2	5 & 9	4

- \*NOTE\*
- ONLY UNITS WITH ADVANCED ELECTRONICS WILL HAVE LIGHTS.
  - FOR HORIZONTAL MOUNTING, CONDUIT OPENINGS MUST FACE DOWNWARDS AND INCLUDE DRIPLOOP.

## VRF II - STANDARD CABLE UNIT

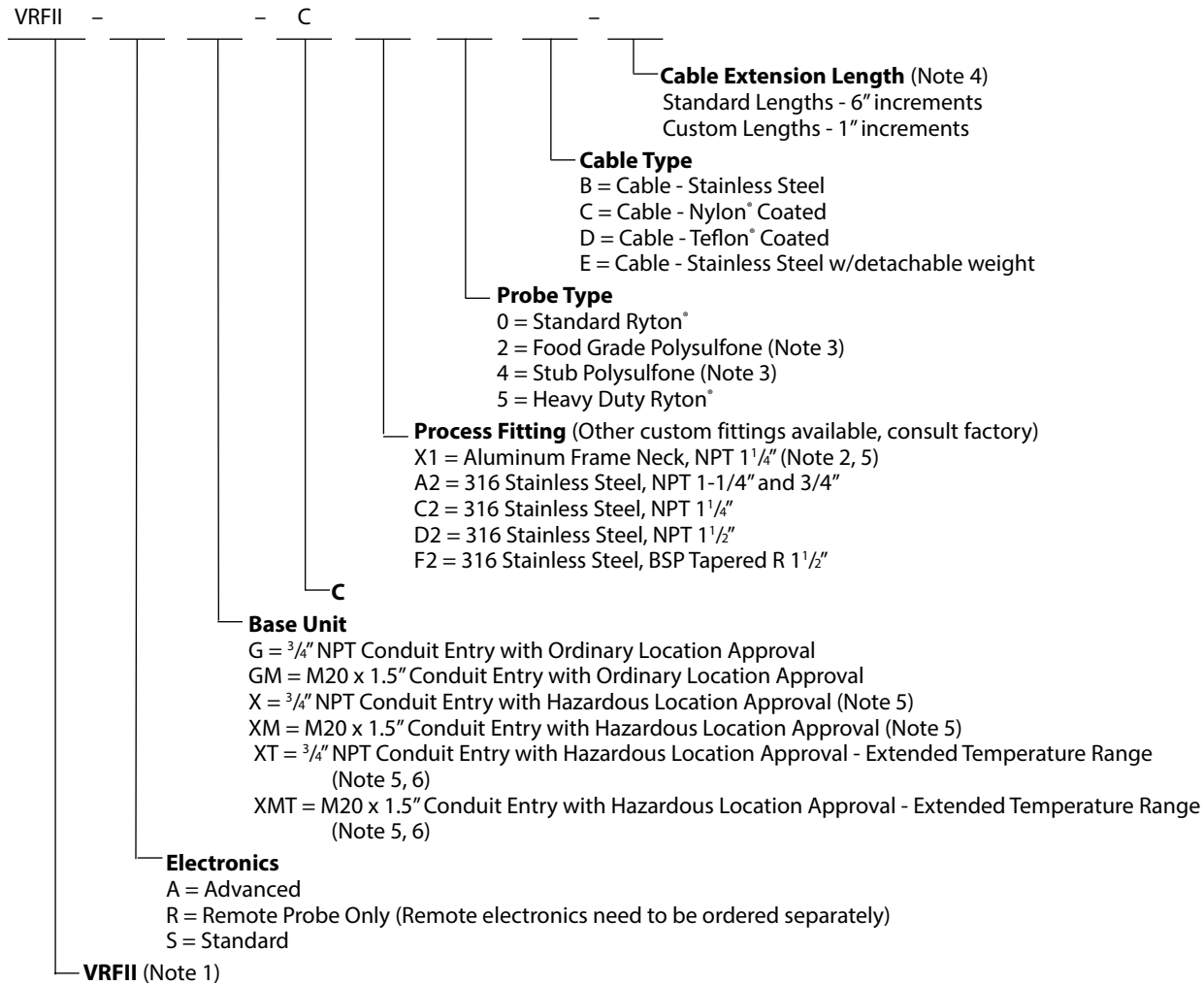

- Notes:
1. Units have powder coated aluminum Housing Finish.
  2. X1 Process Fitting includes a 3/4" NPT 316 stainless steel bin connector.
  3. EPDM food grade gasket is standard.
  4. Maximum length is 540" (13.7 m), minimum length is 12" (30.5 cm). Length cannot be zero.
  5. Process Fitting X1 cannot be used with Hazardous Location Approval.
  6. Extended ambient temperature range is -40° to 158° F (-40° to 70° C).

## STANDARD CABLE UNIT DIMENSIONS

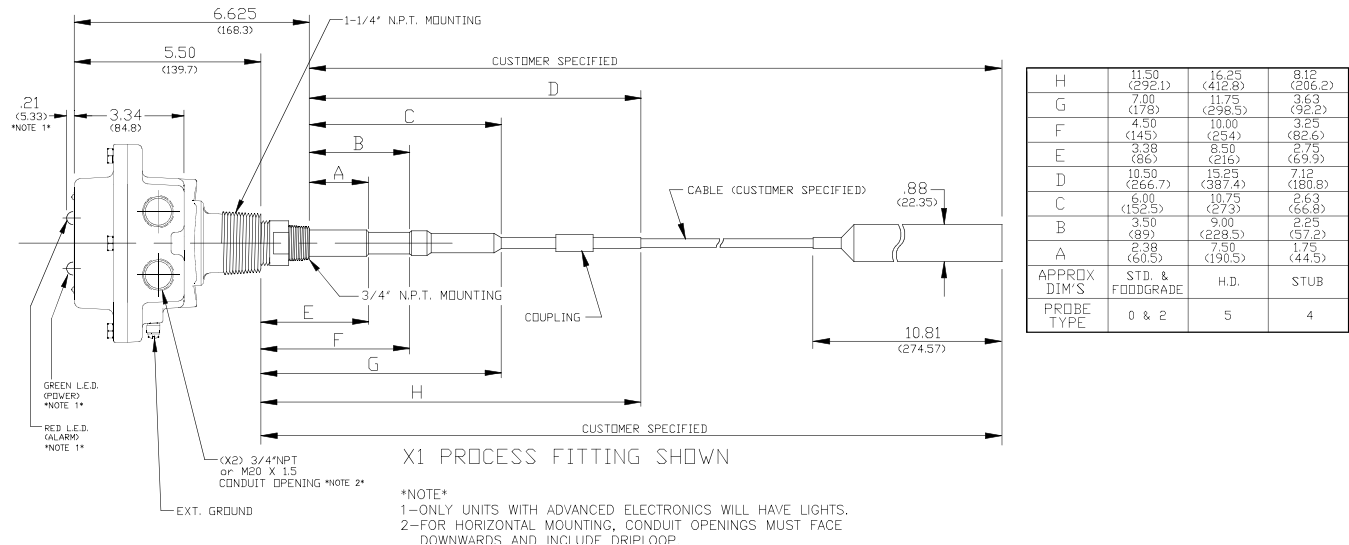

## VRF II - 3A/SANITARY

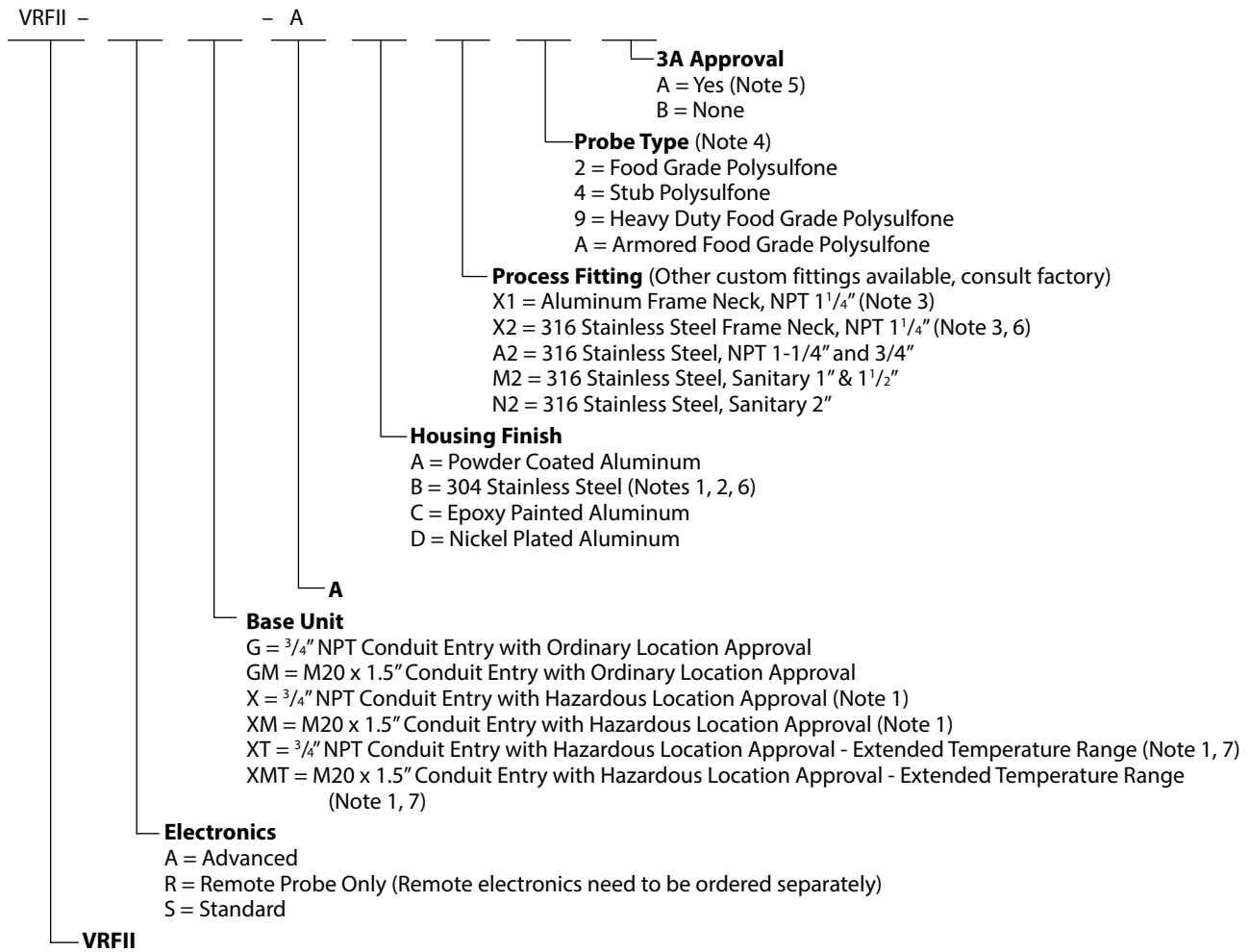

- Notes:
1. Hazardous location approval not available with stainless steel Housing Finish or the X1 Process Fitting; frame dimensions for stainless steel are not standard contact factory for drawings.
  2. Function Test FOB not available with stainless steel Housing Finish.
  3. X1 and X2 Process Fittings include a 3/4" NPT 316 stainless steel bin connector.
  4. EPDM food grade gasket is standard.
  5. 3A Approval only available with Process Fittings M2 or N2 and Probe Types 2, 4 or 9.
  6. Process Fitting X2 and Stainless Steel Housing Finish can only be ordered together.
  7. Extended ambient temperature range is -40° to 158° F (-40° to 70° C).

## 3A/SANITARY DIMENSIONS

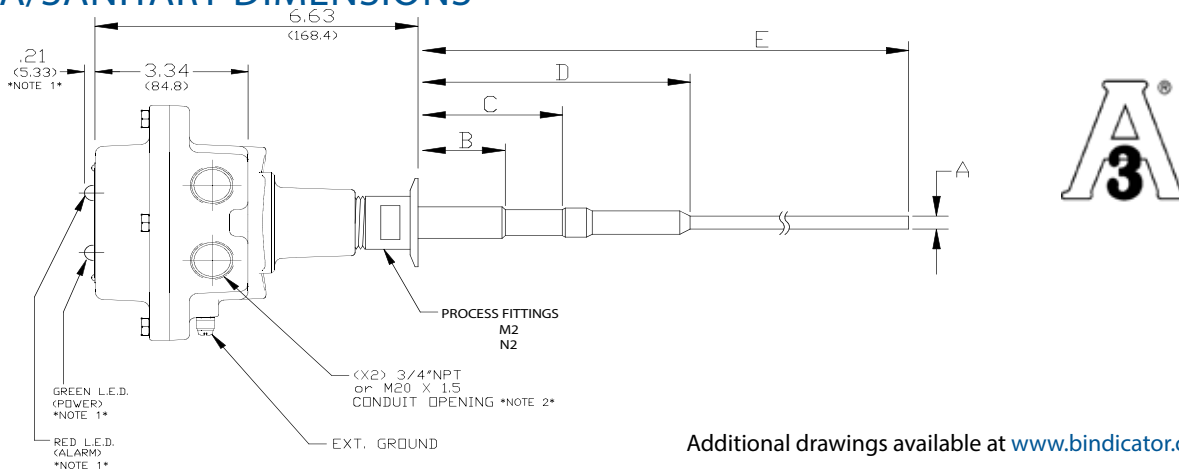

Additional drawings available at [www.bindicator.com](http://www.bindicator.com).

## VRF II - FLUSH MOUNT

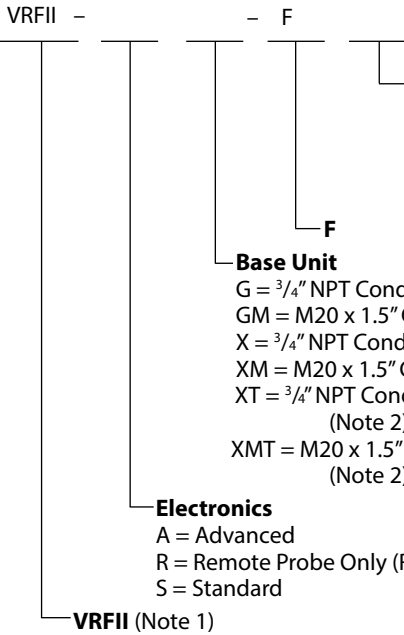

### Probe Type

- 7A = Dome Flush - 3/8" Thickness
- 7B = Dome Flush - 1/2" Thickness
- 7C = Dome Flush - 5/8" Thickness
- 7D = Dome Flush - 3/4" Thickness
- 8 = Flush Probe - 7/16" Thickness

### Base Unit

- G = 3/4" NPT Conduit Entry with Ordinary Location Approval
- GM = M20 x 1.5" Conduit Entry with Ordinary Location Approval
- X = 3/4" NPT Conduit Entry with Hazardous Location Approval
- XM = M20 x 1.5" Conduit Entry with Hazardous Location Approval
- XT = 3/4" NPT Conduit Entry with Hazardous Location Approval - Extended Temperature Range (Note 2)
- XMT = M20 x 1.5" Conduit Entry with Hazardous Location Approval - Extended Temperature Range (Note 2)

### Electronics

- A = Advanced
- R = Remote Probe Only (Remote electronics need to be ordered separately)
- S = Standard

- Notes:
1. Units have powder coated aluminum Housing Finish.
  2. Extended ambient temperature range is -40° to 158° F (-40° to 70° C).

## DOME FLUSH DIMENSIONS

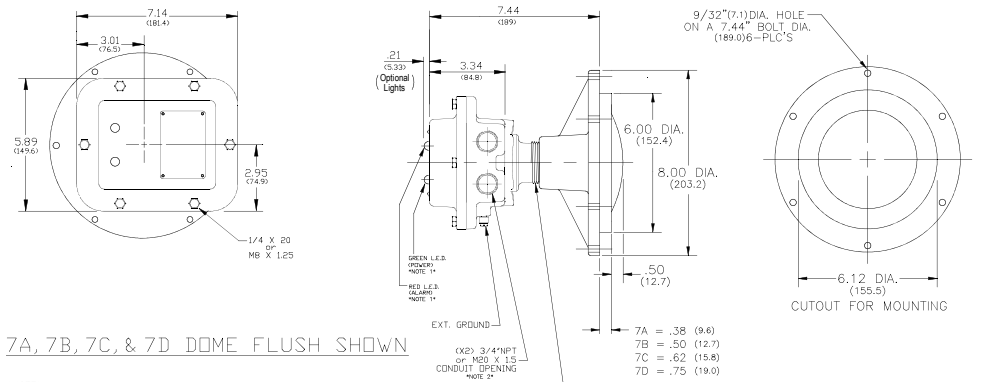

7A, 7B, 7C, & 7D DOME FLUSH SHOWN

\*NOTE\*  
1-ONLY UNITS WITH ADVANCED ELECTRONICS WILL HAVE LIGHTS.  
2-FOR HORIZONTAL MOUNTING, CONDUIT OPENINGS MUST FACE DOWNWARDS AND INCLUDE DRIPLLOOP.

- ### MOUNTING SURFACE PREPARATIONS
1. LAY OUT TWO CONCENTRIC CIRCLES ON BIN WALL AT POINT WHERE THE RF LEVEL CONTROL IS TO BE MOUNTED. ONE CIRCLE TO BE 6-1/8" DIA.; THE OTHER 7-7/16" DIA.
  2. CUT OUT 6-1/8" DIA. CIRCLE.
  3. LAY OUT SIX EQUALLY SPACED HOLES ON 7-7/16" DIA. CIRCLE. DRILL OR TAP FOR 1/4" BOLTS OR CAP SCREWS.

## FLUSH PROBE DIMENSIONS

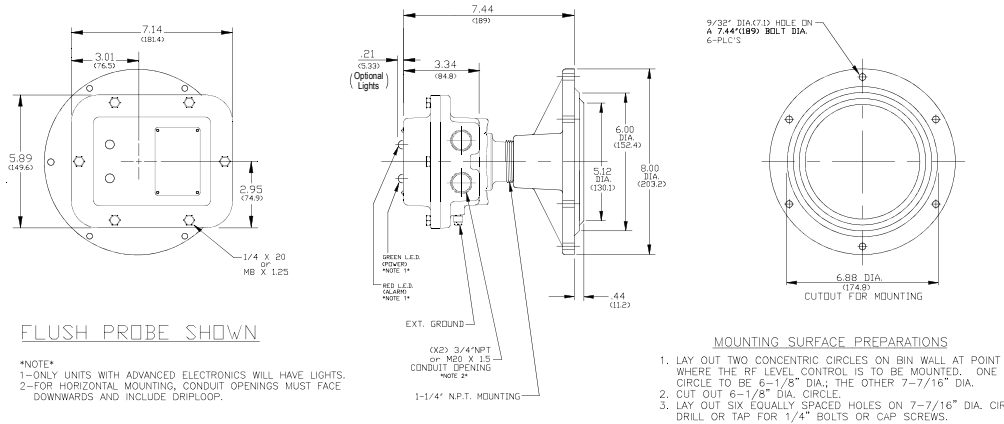

FLUSH PROBE SHOWN

\*NOTE\*  
1-ONLY UNITS WITH ADVANCED ELECTRONICS WILL HAVE LIGHTS.  
2-FOR HORIZONTAL MOUNTING, CONDUIT OPENINGS MUST FACE DOWNWARDS AND INCLUDE DRIPLLOOP.

- ### MOUNTING SURFACE PREPARATIONS
1. LAY OUT TWO CONCENTRIC CIRCLES ON BIN WALL AT POINT WHERE THE RF LEVEL CONTROL IS TO BE MOUNTED. ONE CIRCLE TO BE 6-1/8" DIA.; THE OTHER 7-7/16" DIA.
  2. CUT OUT 6-1/8" DIA. CIRCLE.
  3. LAY OUT SIX EQUALLY SPACED HOLES ON 7-7/16" DIA. CIRCLE. DRILL OR TAP FOR 1/4" BOLTS OR CAP SCREWS.

## VRF II - HIGH TEMPERATURE

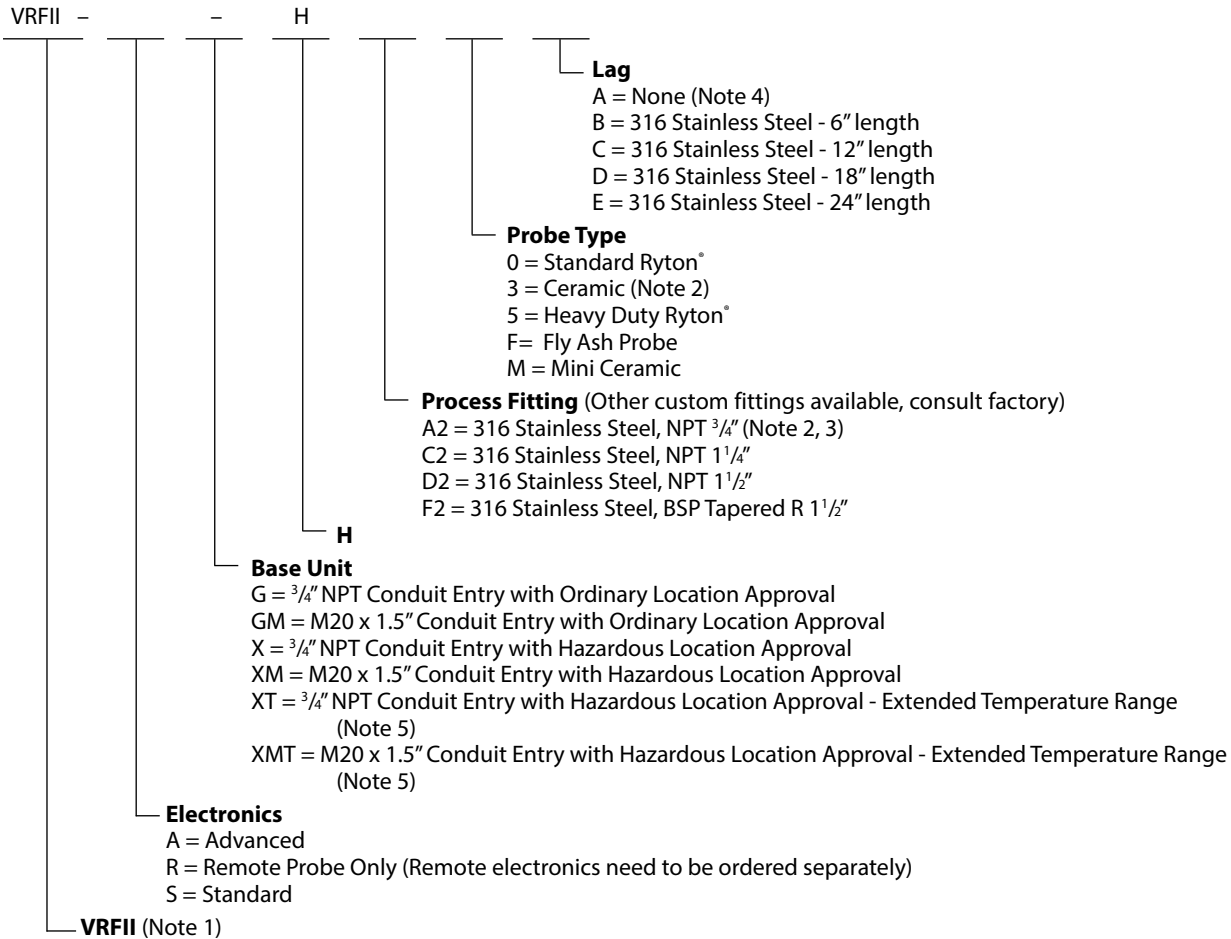

- Notes:
- Units have powder coated aluminum Housing Finish.
  - Ceramic probe is remote only, includes built-in lag of 9 in. (22.9 cm), Lag must be 'None', and it can only be used with Process Fittings C2 through F2, J2 or K2. All material is comprised of 304 stainless steel.
  - Mini Ceramic Probe includes A2 Process Fitting.
  - Can only be used with the ceramic Probe Type
  - Extended ambient temperature range is -40° to 158° F (-40° to 70° C).

## HIGH TEMPERATURE DIMENSIONS

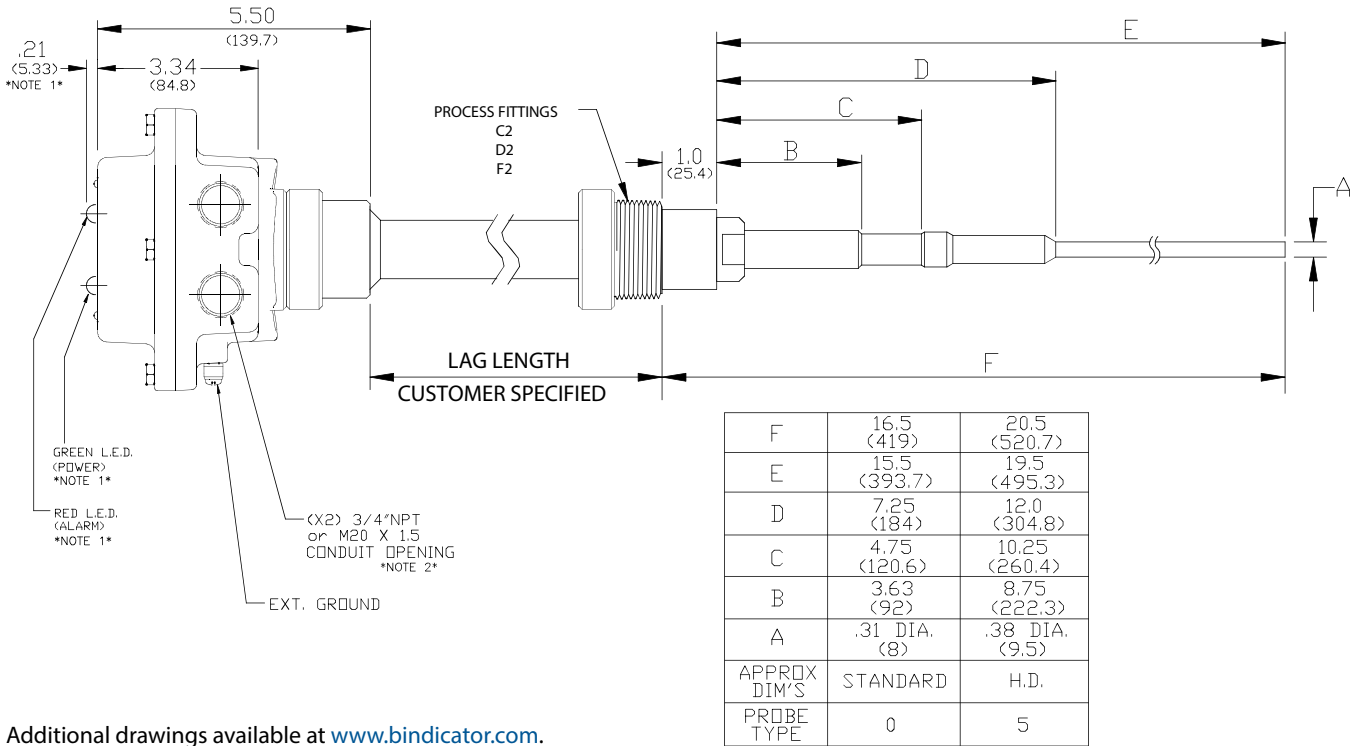

Additional drawings available at [www.bindicator.com](http://www.bindicator.com).

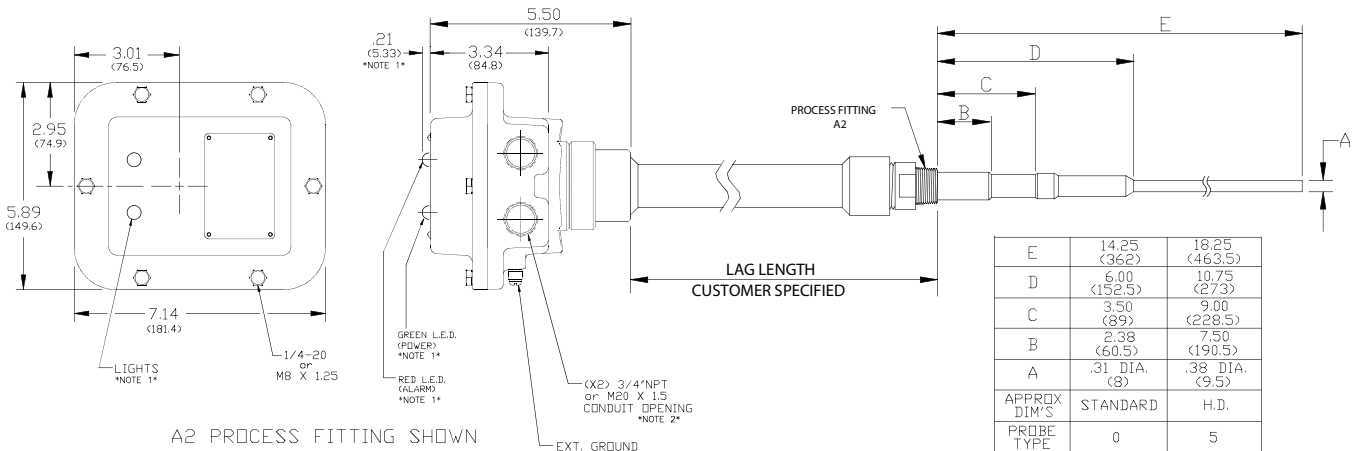

A2 PROCESS FITTING SHOWN

\*NOTE\*  
 1—ONLY UNITS WITH ADVANCED ELECTRONICS WILL HAVE LIGHTS.  
 2—FOR HORIZONTAL MOUNTING, CONDUIT OPENINGS MUST FACE DOWNWARDS AND INCLUDE DRIPLOOP.

## VRF II - EXTENSIONS

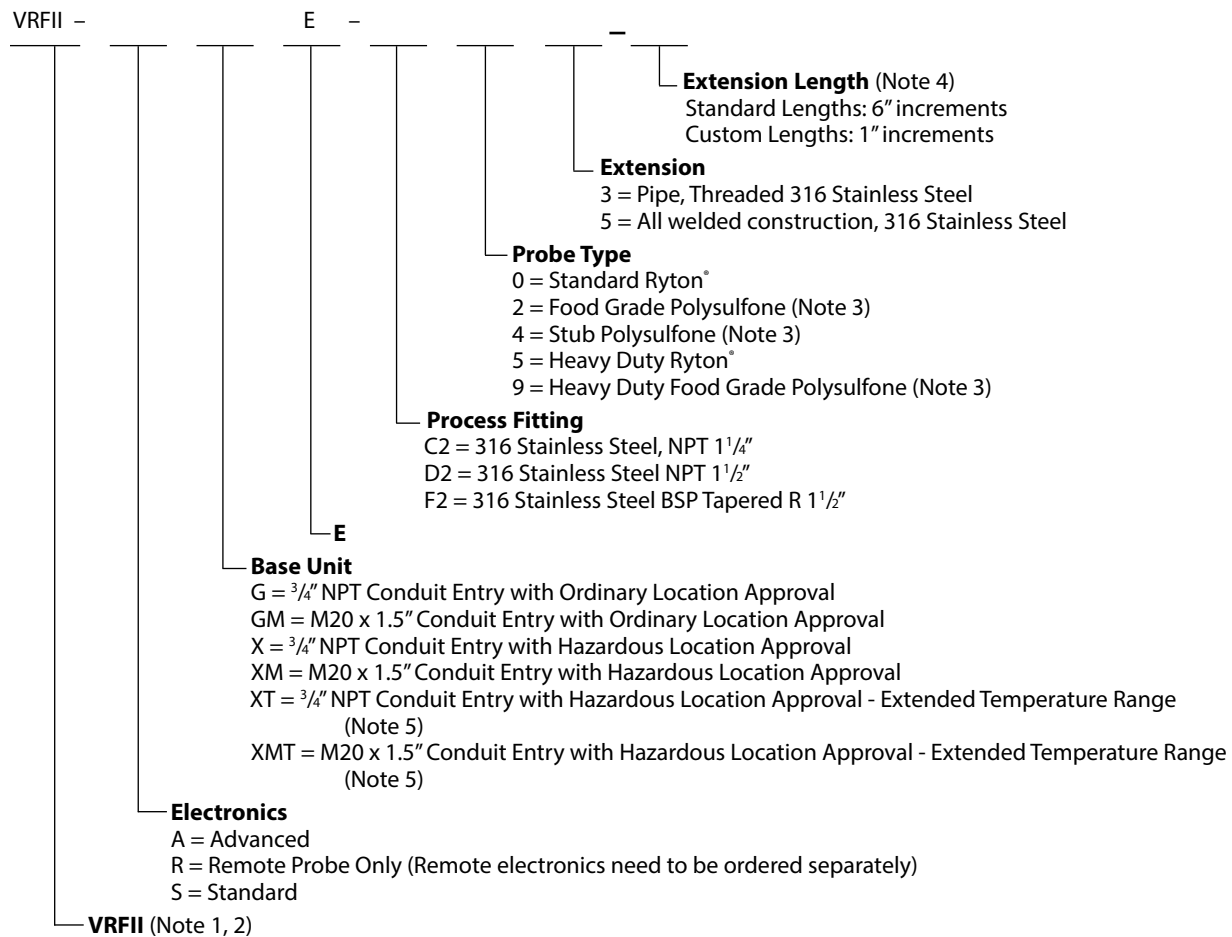

Notes:

1. Units have powder coated aluminum Housing Finish.
2. Extension units do not include 3/4" NPT 316 stainless steel bin connector.
3. EPDM food grade gasket is standard.
4. Maximum extension is 180 in (4.6 m), minimum length is 3 in. (7.6 cm). Length cannot be zero.
5. Extended ambient temperature range is -40° to 158° F (-40° to 70° C).



**EXTENSION DIMENSIONS**

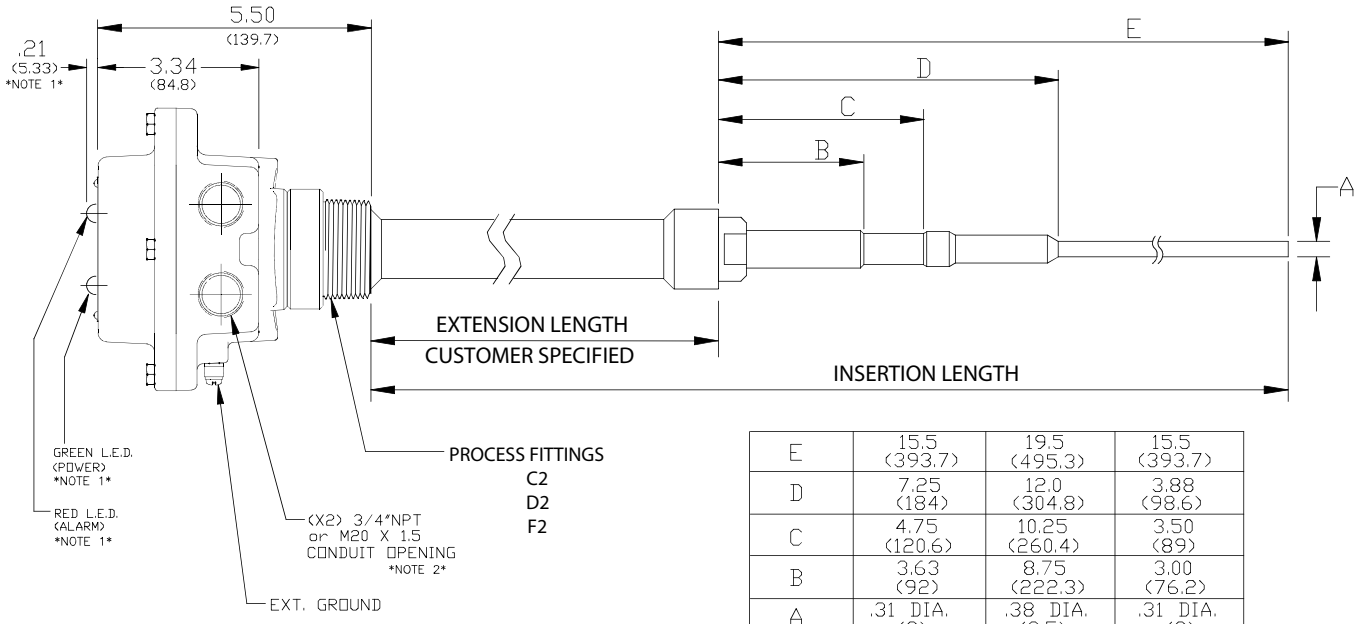

E	15.5 (393.7)	19.5 (495.3)	15.5 (393.7)
D	7.25 (184)	12.0 (304.8)	3.88 (98.6)
C	4.75 (120.6)	10.25 (260.4)	3.50 (89)
B	3.63 (92)	8.75 (222.3)	3.00 (76.2)
A	.31 DIA. (8)	.38 DIA. (9.5)	.31 DIA. (8)
APPROX DIM'S	STD. & FOODGRADE	H.D.	STUB
PROBE TYPE	0 & 2	5 & 9	4

Additional drawings available at [www.bindicator.com](http://www.bindicator.com).

## VRFII - ELECTRONICS REMOTE

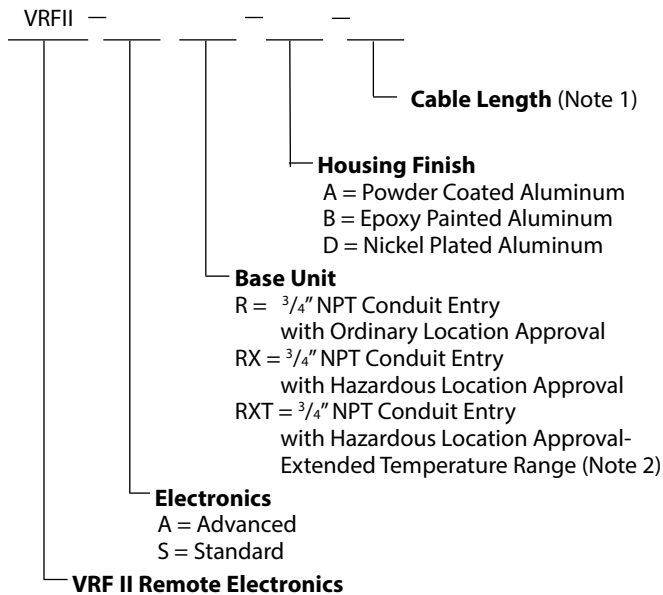

## REMOTE DIMENSIONS

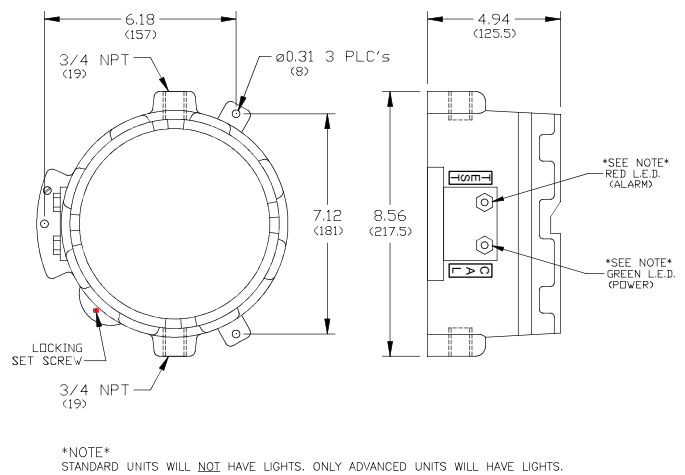

**Notes:**

1. Maximum cable length is 100 ft (30.5 m) and is high temperature cable; leave blank if not used. Standard lengths are 1 ft increments.
2. Extended ambient temperature range is -40° to 158° F (-40° to 70° C).

## PROBE SPECS

		MAX TEMP °F (°C)	PROBE MATERIAL	PROBE LENGTH* IN (CM)
0	Standard Ryton®	450 (232)	316 SS/Ryton®	15.25 (387.5)
1	Standard Kynar® Coated	250 (121)	316 SS/Kynar®	15.25 (387.6)
2	Food Grade Polysulfone	300 (149)	316 SS/Polysulfone	15.25 (387.7)
3	Ceramic	1,000 (537)	316 SS/Ceramic	27.75 (704.9)
4	Stub Polysulfone	300 (149)	316 SS/Polysulfone	15.25 (387.7)
5	Heavy Duty Ryton®	450 (232)	316 SS/Ryton®	19.25 (489.0)
6	Heavy Duty Kynar® Coated	250 (121)	316 SS/Kynar®	19.25 (489.0)
7A-D	Dome Flush	200 (93)	316 SS/Epoxy	Flush Mounted
8	Flush Probe	200 (93)	316 SS/Epoxy	Flush Mounted
9	Heavy Duty Food Grade Polysulfone	300 (149)	316 SS/Polysulfone	19.25 (489.0)
A	Armored Food Grade	230 (110)	Polysulfone covered by 316 SS sleeve and food grade epoxy	19.25 (489.0)
F	Fly Ash Probe	450 (232)	316 SS/Ryton®	19.25 (489.0)
J	Jumbo	200 (93)	316 SS/Thermoset Epoxy	2.33 (5.9)
M	Mini Ceramic	700 (371)	316 SS/Ceramic	9.00 (22.9)
T	Teflon® Jacketed Standard	250 (121)	316 SS/Teflon® and Hastelloy® C process connection	15.25 (387.7)
U	Teflon® Jacketed Heavy Duty	250 (121)	316 SS/Teflon® and Hastelloy® C process connection	19.25 (489.0)

\* From bottom of 1 1/4" fitting to tip of probe; process connections may alter length of probe. See drawings for additional details.

## PROBE MODIFICATIONS AND OPTIONS

Probe Attachments for Heavy Duty Probes Only		When to Use
LHF110030	Rigid Tip Extension - 12" (300 mm)	To extend active length for bertical mounting
LHF110031	Rigid Tip Extension - 24" (600 mm)	
LHF110032	Rigid Tip Extension - 36" (900 mm)	
LHF110033	Rigid Tip Extension - 48" (1200 mm)	
LHF110034	Rigid Tip Extension - 60" (1500 mm)	
LHF110035	Flexible Tip Extension - 12" (300 mm)	For use with excessive side loading
LHF110036	Flexible Tip Extension - 24" (600 mm)	
LHF110037	Flexible Tip Extension - 36" (900 mm)	
LHF110038	Flexible Tip Extension - 48" (1200 mm)	
LHF110039	Flexible Tip Extension - 60" (1500 mm)	
LRF110851	Cable/Weight Tip Extension (84" maximum) Specify length in inches	

Probe Attachments		
LRF110085	Sensitivity Sleeve - $\frac{3}{4}$ ", Standard Probe	Adds mechanical sensitivity by providing more surface contact below material and probe
LRF110086	Sensitivity Sleeve - $1\frac{1}{4}$ ", Standard Probe	
LRF110199	Sensitivity Sleeve - $\frac{3}{4}$ ", Heavy Duty Probe	
LRF110766	Sensitivity Sleeve - $1\frac{1}{4}$ ", Heavy Duty Probe	Provides additional mechanical sensitivity to tip of probe
LRF120058	Tear Drop Sensitivity Attachment, Standard Probe - $1\frac{1}{4}$ "	
LRF120081	Tear Drop Sensitivity Attachment, Heavy Duty Probe - $1\frac{1}{4}$ "	
LRF120089	Tear Drop Sensitivity Attachment, Standard Probe - $\frac{3}{4}$ "	
LRF120090	Tear Drop Sensitivity Attachment, Heavy Duty Probe - $\frac{3}{4}$ "	
LRF120145	Tear Drop Sensitivity Attachment, Ceramic Probe - $1\frac{1}{4}$ "	

Remote Calibration Modules	
LRF110017	Remote Pushbutton Calibration Module
LRF110073	Remote Keyswitch Module (for use with Calibrate/Function Test Only)

Probe Modifications	
	Welded Tip Extension
	Bent Probe (Exact location and degree of bend required)
	Shortened Probe (Exact length required)
	Kynar <sup>®</sup> Coated Tip Extension

## SPECIFICATIONS

FUNCTIONAL	
Power Requirements	Universal, 120 - 240 VAC 50/60 Hz or 24 - 48 VDC
Power Consumption - STANDARD	10 W AC; 3 W DC
Power Consumption - ADVANCED	11 W AC; 4 W DC
Fuse	Fast Blow, 1A 300 V (Not User Serviceable)
Ambient Temperature	Ordinary Location: -40° to 158° F (-40° to 70° C) Hazardous Location: -4° to 140° F (-20° to 60° C) Hazardous Location, Extended: -40° to 140° F (-40° to 60° C)
Process Temperature	-20° to 302° F (-29° to 150° C) Standard Up to 500° F (Up to 260° C) with Extension 3 and Lag
Probe Temperature Range	-40° to 993° F (-40° to 534° C) depending on probe
Outputs	
Main Relay	8 A DPDT @ 240 VAC or 30 VDC (resistive)
Auxiliary Relay - ADVANCED Only	0.46 A SPDT @ 150 VAC or 1 A @ 30 VDC
PERFORMANCE	
Pressure Rating	150 psi (10.5 kg/cm <sup>2</sup> ) with 3/4" NPT; 50 psi (3.5 kg/cm <sup>2</sup> ) with 1 1/4" NPT
Time Delay - STANDARD	Field Adjustable; 0.2 - 6 seconds
Time Delay - ADVANCED	Field Adjustable; 0 - 150 seconds
Fail Safe	Field Selectable; high/low level
Sensitivity - STANDARD	Field Adjustable; minimum 1.5 pf
Sensitivity - ADVANCED	Field Adjustable; minimum 0.5 pf
Maximum Particle Size	9/16" (14.3 mm)
PHYSICAL	
Enclosure Material	Polyester or epoxy coated aluminum or 304 SS
Dual Conduit Entry	3/4" NPT or M20 x 1.5
Mounting Plate Material	Mild Steel, 304 SS
Extended Pipe Material	Galvanized or 316 SS
Shipping Weight	Integral, non-extended 10 lb (4.5 kg)

## AGENCY APPROVALS

### UL (US and Canada)

- Ordinary Location, Type 4X; IP66
- Hazardous Locations, Type 4X
  - Explosion Proof, Class I, Div 1, Groups C, D
  - Dust Ignition Proof, Class II, Div 1, Groups E, F, G
  - Intrinsically Safe



### ATEX/IEC/IECex (Pending)

- Dust and Gas Categories



### CE

- Electromagnetic Compatibility Directive
- Low Voltage Directive

### 3A SANITARY



150 Venture Boulevard · Spartanburg, SC 29306  
 Tel: (800) 778-9242 · (864) 574-8060  
 Fax: (864) 574-8063  
 E-mail: [sales@bindicator.com](mailto:sales@bindicator.com)  
[www.bindicator.com](http://www.bindicator.com)

**venture**  
 MEASUREMENT  
 VRF180713 Rev. D  
 2015 All rights reserved.  
 All data subject to change without notice.