

AKO Temperature Regulator Type Series 220.0540

deliverable sizes: 25, 32, 40, 50, 65, 80, 100 mm

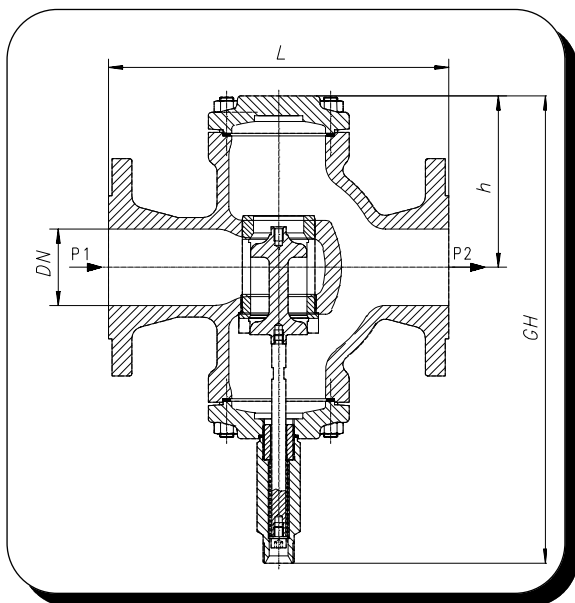

Technical Data:

double-seat valve

two-way-valve
working as closing-valve

materials:

- housing

cast iron (GG 25)

- inner parts

stainless steel

working temperature

up to 230 °C (s. DIN 2401!)

a cooling-transition piece in case of temperatures over 150 °C
is necessary for the protection of the heat sensor

working pressure

up to 16 bar

nominal pressure

PN 16

connection

flange DIN 2533

Prepared for the connection of a suitable heat sensor

Functioning

The control of the regulating valve is effected through the change in volume of the expansion liquid of the heat sensor under temperature influence. The valve closes with increasing temperature proportionally to the heat balance taken up by the heat sensor.

Application

Temperature regulation within pyrometric plants and cooling plants. Usable for liquids, steam and nonburnable gases. For special applications or special mediums we kindly ask you to let us have your inquiries.

order-no.	DN	L	GH	h	KVs	Δp adm.	Y_h stroke	heat sensor	K_R	weight kg
220.0540-025	25	160	300	90	8,0	16	6	230.0300A000	0,20	15,0
220.0540-032	32	180	320	100	12,5	16	8	230.0300A000	0,20	16,0
220.0540-040	40	200	320	110	20,0	16	10	230.0300A000	0,20	17,0
220.0540-050	50	230	310	115	32,0	16	12	230.0300A001	0,13	22,0
220.0540-065	65	290	380	146	50,0	16	14	230.0300A001	0,13	30,0
220.0540-080	80	310	420	170	80,0	16	16	230.0400A001	0,40	42,0
220.0540-100	100	350	470	190	120,0	16	18	230.0400A003	0,40	45,0
220.0540-125	125	400	530	220	195,0	16	20	230.0500A003	0,52	72,0
220.0540-150	150	485	590	250	275,0	16	22	230.0500A003	0,52	80,0

In this list you will find the standard combination of valve and heat sensor. A combination of each other offered heat sensor with each valve is possible, however (see data sheet I 230.xxx).

The indicated K_R -value indicates the stroke of the heat sensor at a temperature difference of 1 °K.