

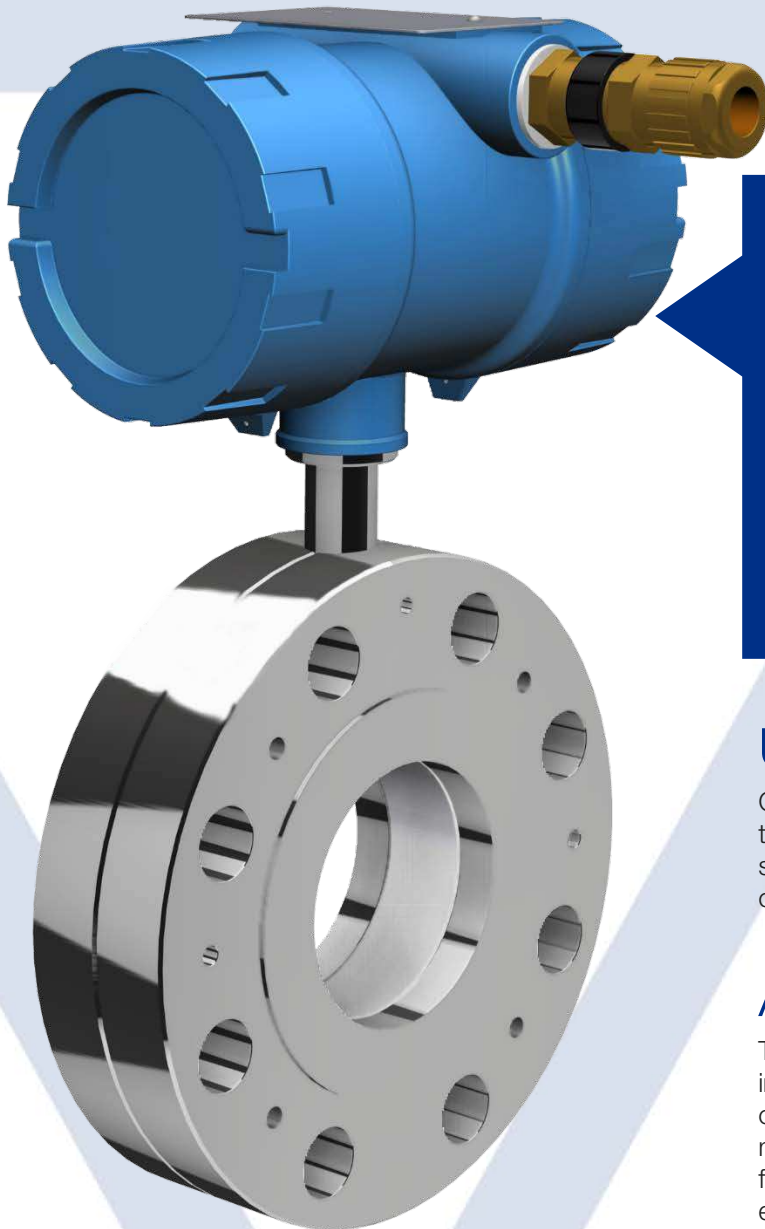

Interface detection pipe probe

TSS90 DN(ANSI) .. SF TRV MTI50/0 F3 AGd ExdG



- Measurement electronics factory set
- High-resolution measuring signal
- Pressure independent, stable measuring signal
- No moving parts
- PTFE-core
- No commissioning plug & process
- Process pressure PN16
- Process temperature 100 °C
- Insensitive to contamination

Use

Can be used at oil terminals and at refineries at the exit of the stripping line or in the production plant, as well in storage tanks. For liquid/liquid phase separation of organics to aqueous media.

Application

The pipe probe manufactured with stainless steel flanges in the standard version as sandwich-structured probe, combined with a PTFE inner body - including the measurement system - is applied as interface pipe probe for interface detection, separation, monitoring or as empty signal.



Serial-no:

TAG-no:

Model code:

TSS90 DN(ANSI) .. SF TRV MTI 50/0 F3 AGd ExdG

TSS90	Pipe probe with PTFE measuring electrode in steel plane flange sandwich construction
DN	Flange DN 50, 80, 100, 125, 150 PN16 form A to EN 1092-1 ANSI 2, 3, 4" 150lbs ASTM A182, ASME B16,5 RF
SF	Process connection on steel flange
TRV	Teflon® PTFE measuring body s = 1.2 mm, stainless steel 1.4404 flange, VITON seal
MTI	Measuring electronics device built in process condition selected MTI 50/.. AEO2 K
F3	For rainwater monitoring with min. change of MV up to 100 µS/cm or for phase separation with el. conductive organics up to 4000 µS/cm
A	Analog measurement technology for interphase detection, product monitoring, full and empty signal
Gd	Measuring electronics – protective housing, (Outdoor), seawater-proof (Offshore) blue RAL 5007, seal: Silicon, EX/flameproof IP 68, cable gland brass Exd IP 66 M20 × 1.5, cable clamping range 9.5-16 mm

Probe Ex-protection: SEV 09 ATEX 0133 X CE 0036/1254

ExdG | (Gas-) Ex version (probe/MTI) II 1/2 G Ex d ia IIC T6 Ga/Gb

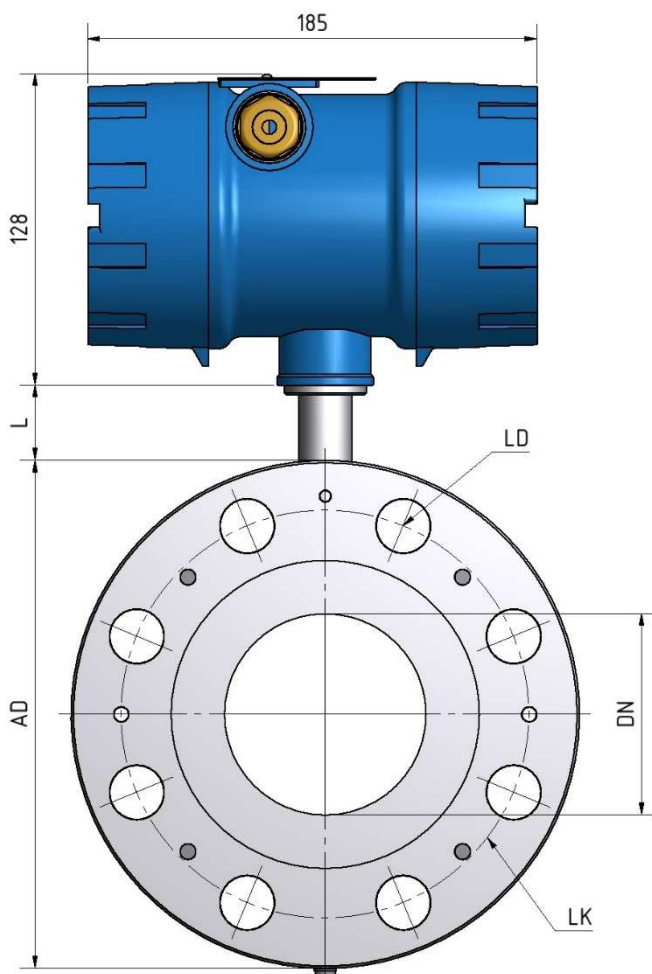

Technical data

Temperature range

-20 ... +100 °C medium | -20 ... +60 °C connection head

Cleaning temperature 210 °C max. 10 min pressureless (CIP)

Pressure -0.5 bar to max. 16 bar / 150 lbs. standard

Measuring principle Impedance

Measuring range DK 1.20 ... > 80
measuring value water 2720 Imp.

Resolution < 6 Impulses

Use for rainwater monitoring

MTI F3: 0...100 µS/cm | MV max. >10'000 µS/cm

Basic capacity Cp: 38 pF / Rp: 2.8 MΩ

Integration time 40-400 ms / 0-3750 Imp

Use in Ex-Zone II 1/2G Zone 0

Measuring electrode PTFE-layer thickness s = 1.2 mm

Application Interface detection for separation and monitoring

Measuring electronics Round housing MTI 50/.. AEO2K

Protection connection head round IP68 to EN 60529

Wiring

Shielded 2-core cable 0.75 mm² twisted CY to all evaluation devices mipromex® cable length up to 1000 m or max.
C= 150 nF / R = 60 Ω/km line impedance

Connection to evaluation unit mipromex® MIQ / MAT / MLS Exd

Article-n° 02.29.11.9000x

Nominal width	AD	DN	LD drilling	LK	Mounting height	FLA incl. Gasket
DN 50 PN 16/40	165	50	4 x \varnothing 18	125	40	44
DN 80 PN 16/40	200	80	8 x \varnothing 18	160	40/48	44/52
DN 100 PN 16	220	100	8 x \varnothing 18	180	40	44
DN 125 PN16	250	125	8 x \varnothing 18	210	44	48
DN 150 PN16	285	150	8 x \varnothing 20	240	44	48
ANSI 2" 150 lbs	152.4	50	4 x \varnothing 19.1	120.7	40	44
ANSI 2" 300 lbs	165.1	50	8 x \varnothing 19.1	127.0	44.6	48.6
ANSI 3" 150 lbs	190.5	80	4 x \varnothing 19.1	152.4	47.8	51.8
ANSI 3" 300 lbs	209.5	80	8 x \varnothing 22.3	168.1	56.8	60.8
ANSI 4" 300 lbs	254.0	100	8 x \varnothing 22.3	200.1	63.4	67.4

Technical data on-site MTI F3 measuring electronics

Design type

Plug-in electronics with square stainless cover in the protective housing, with HF-connection; IP 20

Installation

Protection housing with mounting holes, plug-in electronics pluggable, fixed with 2 screws M4x8

Performance

Linear conversion of an impedance range into a normed digital measurement signal

Use / Display

One-time compensation of basic capacity of the RF cable and uncovered dry probe, LED display for quick adjustment

Dimensions

Square model height x width x length 57 x 80 x 175 mm

Weight electronics

140 g

Ex-power supply / connection wiring (only Ex ia)

Shielded two-wire connection 0.75 mm² twisted CY/EIG to all evaluation devices mipromex® cable length up to 200 m or max. C= 120 nF / R = 30 Ohm line impedance

Transfer signal

Impulse parcel, superimposed on the supply current

Measuring voltage / current

U ~ 14.5 V I ~ 13.5 mA

Nominal data of the supply voltage

Rate data **Ex ia IIC** only for connection to mipromex®-or *TI*K-units
Circuit with the following maximum output values

$U_i \leq 18.9$ V $I_i \leq 49$ mA

$P_i \leq 231$ mW

$C_i = 60$ nF $L_i = 0$ mH

For ignition protection type flameproof enclosure and intrinsic

Safety, **Ex d ia** IIC only for connection to mipromex® Typ M** **** *

Circuit with the following maximum output values

$U \leq 19.3$ V $I \leq 75$ mA

Ambient temperature

-20 ... +60 °C

Storage temperature

-30 ... +80 °C, ideal +20 °C

Measuring range

10 / 20 / 50 / 100 / 200 / 300 respective 0 up to max. 3750 impulses, special ranges available. The resolution range depends on the probe dimension and is product specific.

Resolution

Max. 0.003 pF/impulses

Norm range for pipe tube probe with detached MTI housing

Type TSS90 .../100/200/300

55 pF, type MTI 30/., 50/(0 - 16) basic adjustment range depending on probe and RF cable length, determined by the manufacturer

Basic adjustment range

MTI .../. 0 to 16, 0 to 500 pF

Measurement frequency

~ 2.8 MHz

Linearity

Deviation < 0,1 % (without probe)

Hysteresis

1 measured impulse

Temperature influence 5 – 45 °C

Type MTI .../.A analog: < \pm 3 measuring impulses

Certification



Gas II 1/2G Ex ia Gb IIC T6
II 1/2G Ex d ia IIC T6

RL 2014/34/EU

Inspection report n°: 08-IK-0395.01 with extension 1

Unit can be supplied without Ex-protection

Intrinsically safe Ex-connection:

Measuring electronic MTI ... in a protective housing or tube probe type TSS80

EMC-tested, STS 024 report n° 990102WS

corresponds to EN 1127-1 : 20011

EN 61000-6-2 2005 EN 6100-6-4 : 2007

EN 60079-0 : 2012 EN 60079-11 : 2012



Function

The impedance changes as a function of the dielectric constant and the el. conductivity of the organic and aqueous media, plus in partially filled, horizontal installed pipe probes. The measured impedance at the measuring electronics MTI is transformed directly into a normed digital sum signal and transmitted as a pulse train transmitted to the mipromex®.

Mounting directions

- Installation position of a 3 % slope to vertical, depending on the application (see mounting directions for TSS)
- Installation independent of the flow direction
- Installation between two smooth flanges or flared, loose flanges only with special installation protection gaskets
- Caution! Note flange to flange distance for different nominal widths
- Additional flat gaskets "Gylon" (with appropriate tightening torque)
- Internal installation guidelines always have to be followed and suitable sealing types used.
- Observe internal safety regulations for open tanks
- Installation in pipes with appropriate nominal diameter with flat gasket and tightening torques (see mounting directions for TSS90)
- The pipe insulation must not enclose the cooling rod
- Ambient temperature: max. allowed temperature in the connection head must not exceed +60 °C, if pipe probe is insulated and measuring electronics is detached installed
- The connection electronics MTI must be mounted at pipe temperatures of >60 °C horizontal or downwards.
- Pressure tests have to be conducted with mounted probe
- Caution! Probe body is only leak-proof when flanged in.

Disassembly instructions

- Empty tank and flush with nitrogen or water according to operating instructions (observe internal safety regulations)
- Disconnect electrical connections. Dismount probe, lift at the flange. Careful, residual liquid may leak out
- Data sheets for personal safety purpose need to be added with repair shipments to aquasant.

Electrical directions

- Wiring must comply with the circuit and grounding diagram.
- Connections to MTI clamps 1/2, protected against polarity reversal, suitable for wire cross section 0.2 – 1.5 mm²
- The connecting cable has to suit the demands at the measuring circle.
- MTI-housing lid in [Ex ia] zone can be opened under live-line working.
- Output signal of mipromex[®] is a pulse modulated signal $U_0 \leq 18.9 \text{ V}$

Basic circuit diagram

Probe connection to evaluation unit mipromex[®]
 Connection diagram MRM4 Monorack DIN housing

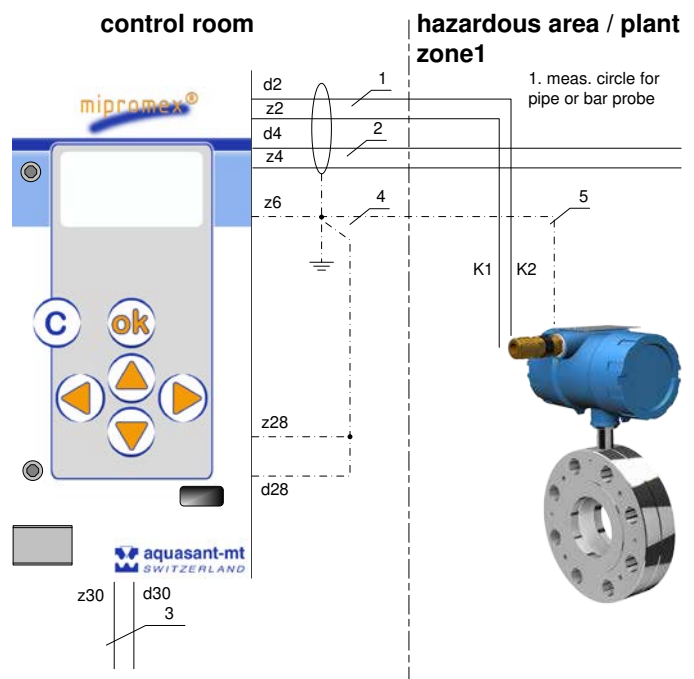

Certificates

Explosion protection (ATEX)
 EC-type examination SEV 09 ATEX 0133 X
 - Ex certification according to the directive 2014/34 EU
 - Confidential test report no: 08-IK-0395.01

CE-Mark

The probe fulfills the legal requirements according to the EC directives. CE 1254